

MEMBER	NO. OFF	TYPE, SIZE & SHAPE	NO. OFF IN EACH	TOTAL NO OFF	CUTTING LENGTH (mm)	CODE	A mm	B mm	C mm	D mm	E/R mm	MASS kg
L = 1500 SPRAYED CORNER	Y10-01	2	185	20	185							
	Y10-02	2	335	20	335							
	Y10-03	2	485	20	485							
	Y10-04	14	580	20	580							
	Y10-05	2	1050	20	1050							
	Y10-06	2	1205	20	1205							
	Y10-07	2	1355	20	1355							
	Y10-08	4	1450	20	1450							
	R10-09	6	450	83	150			55	100			
L = 2000 SPRAYED CORNER	Y10-01	2	185	20	185							
	Y10-02	2	335	20	335							
	Y10-03	2	485	20	485							
	Y10-04	22	580	20	580							
	Y10-05	2	1550	20	1550							
	Y10-06	2	1705	20	1705							
	Y10-07	2	1855	20	1855							
	Y10-08	4	1950	20	1950							
	R10-09	6	450	83	150			55	100			
L = 2500 SPRAYED CORNER	Y10-01	2	185	20	185							
	Y10-02	2	335	20	335							
	Y10-03	2	485	20	485							
	Y10-04	28	580	20	580							
	Y10-05	2	2050	20	2050							
	Y10-06	2	2205	20	2205							
	Y10-07	2	2355	20	2355							
	Y10-08	4	2450	20	2450							
	R10-09	6	450	83	150			55	100			

MEMBER	NO. OFF	TYPE, SIZE & SHAPE	NO. OFF IN EACH	TOTAL NO OFF	CUTTING LENGTH (mm)	CODE	A mm	B mm	C mm	D mm	E/R mm	MASS kg
L = 1500 RECTANGULAR PANEL	Y10-01	22	580	20	580							
	Y10-02	5	1450	20	1450							
	R10-03	6	450	83	150			55	100			
L = 2000 RECTANGULAR PANEL	Y10-01	28	580	20	580							
	Y10-02	5	1950	20	1950							
	R10-03	6	450	83	150			55	100			
L = 2500 RECTANGULAR PANEL	Y10-01	34	580	20	580							
	Y10-02	5	2450	20	2450							
	R10-03	6	450	83	150			55	100			

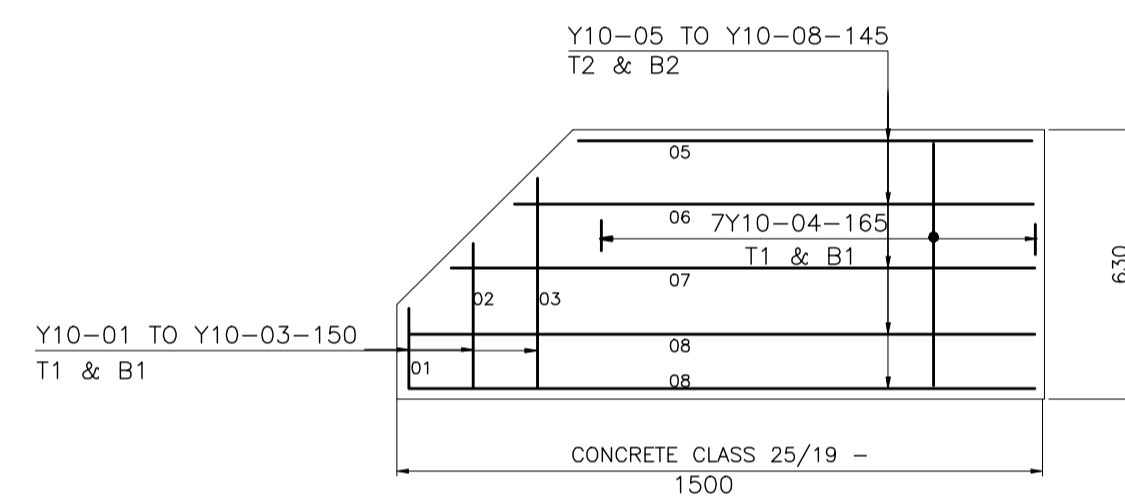

SPLAYED CORNER L=1500

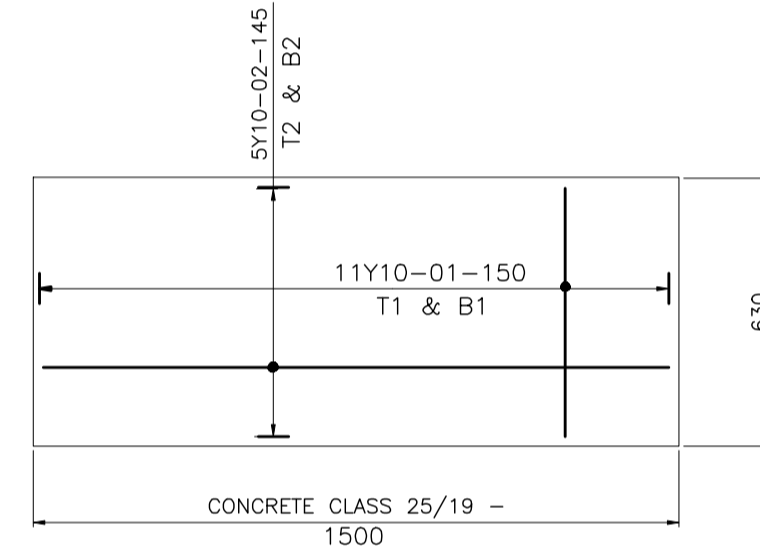

RECTANGULAR PANEL L=1500

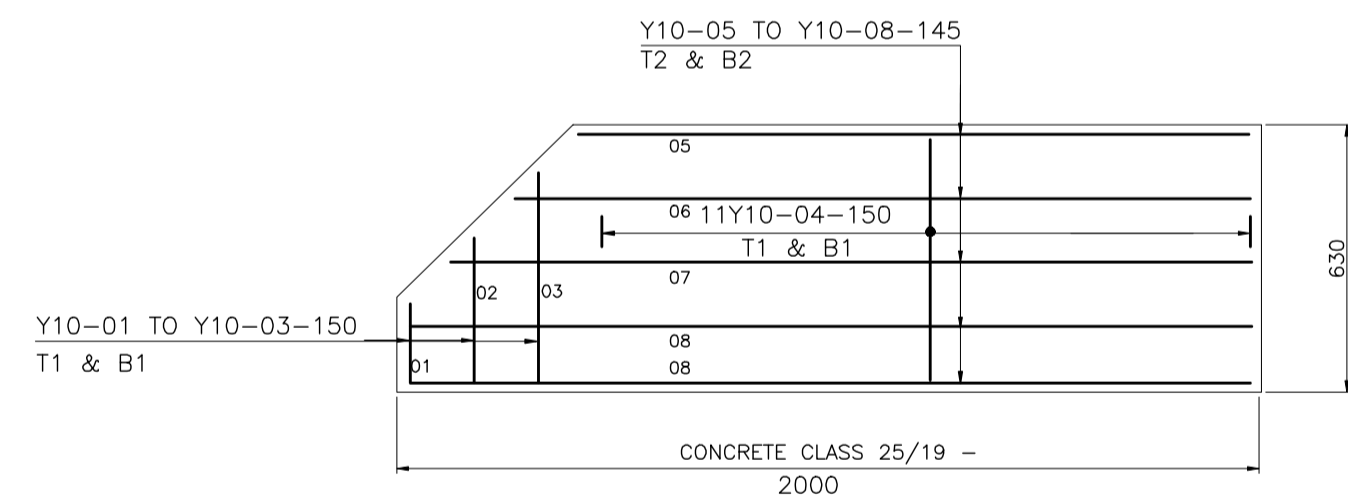

SPLAYED CORNER L=2000

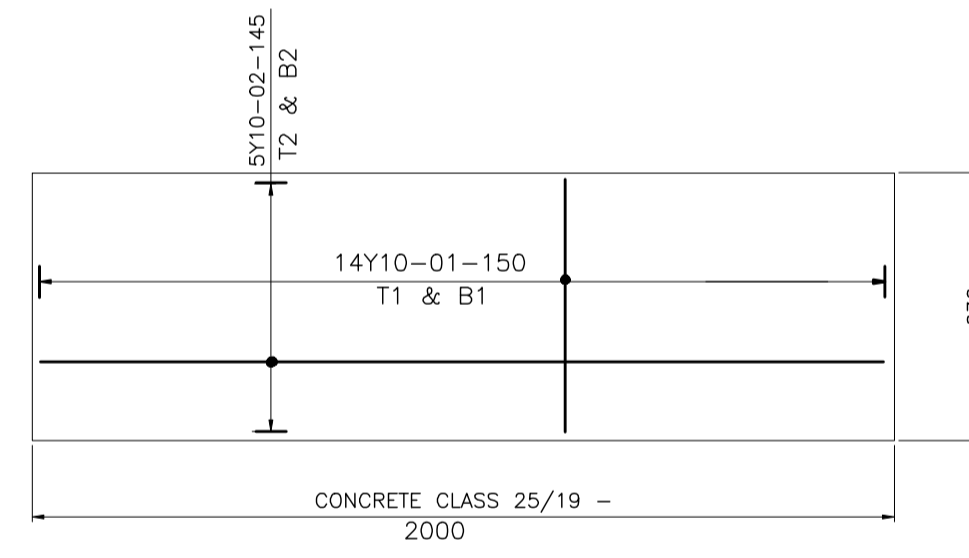

RECTANGULAR PANEL L=2000

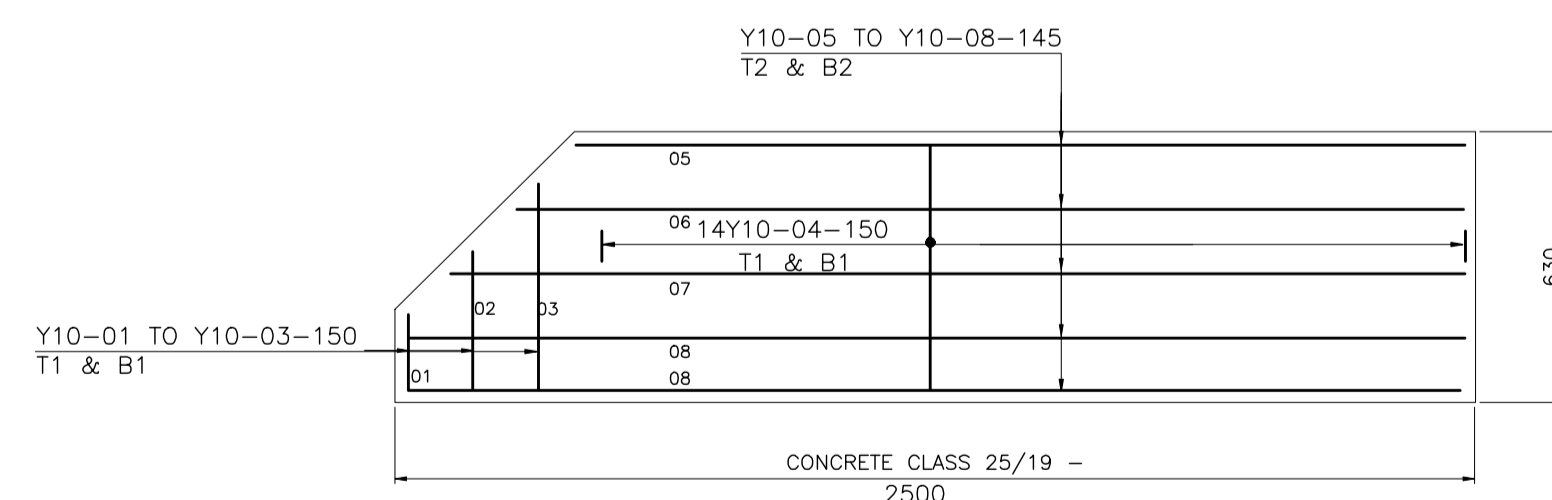

SPLAYED CORNER L=2500

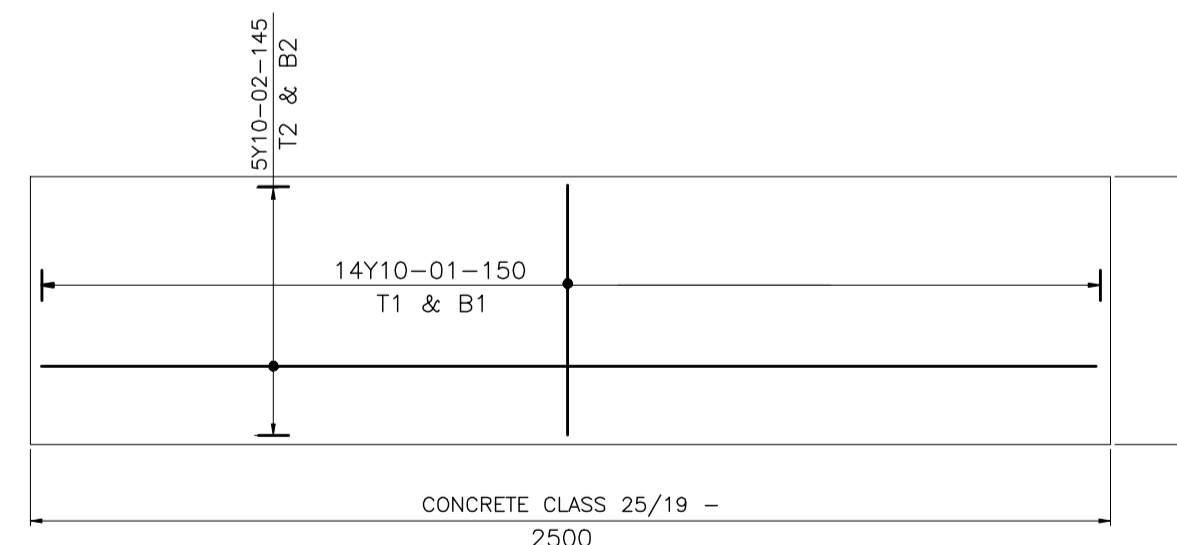

RECTANGULAR PANEL L=2500

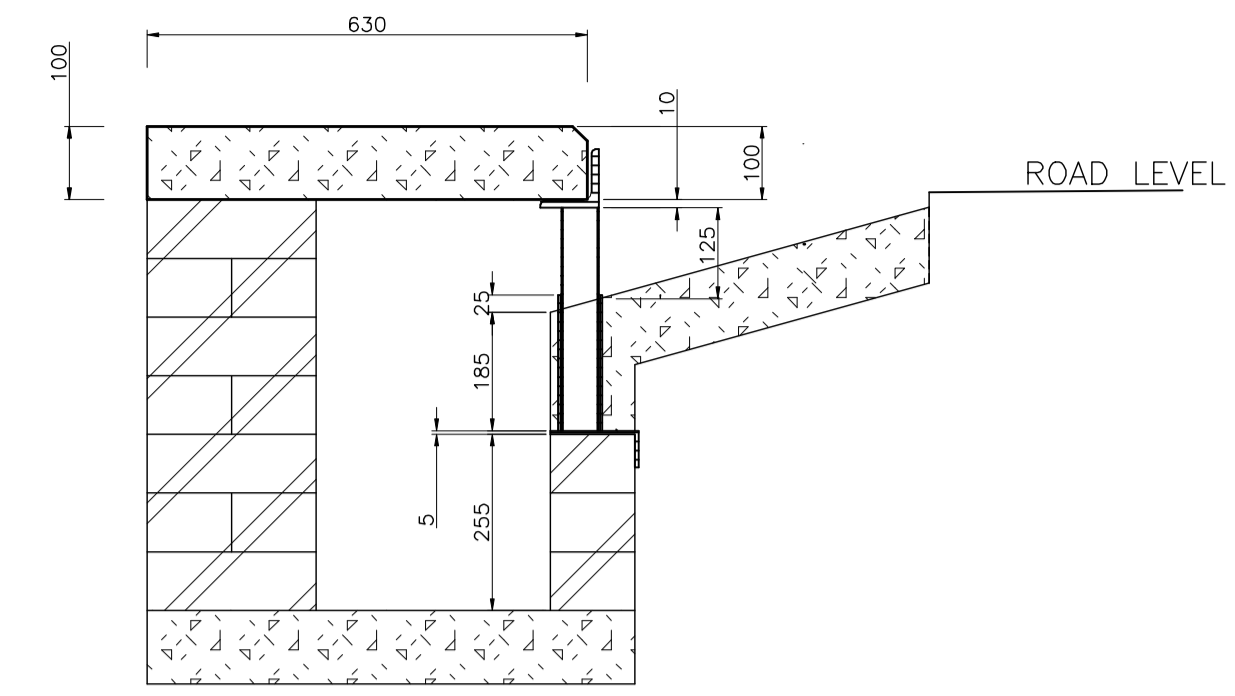

CATCHPIT X-SECTION

NTS

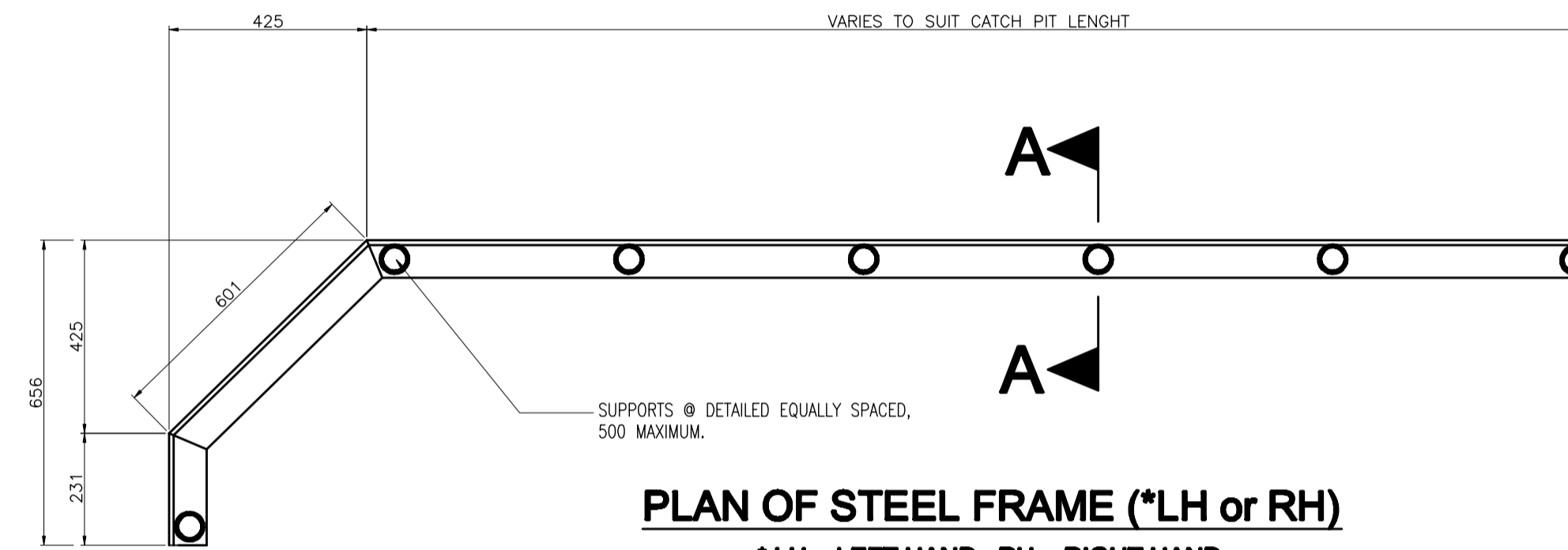

PLAN OF STEEL FRAME (*LH or RH)

* LH = LEFT HAND : RH = RIGHT HAND

NTS

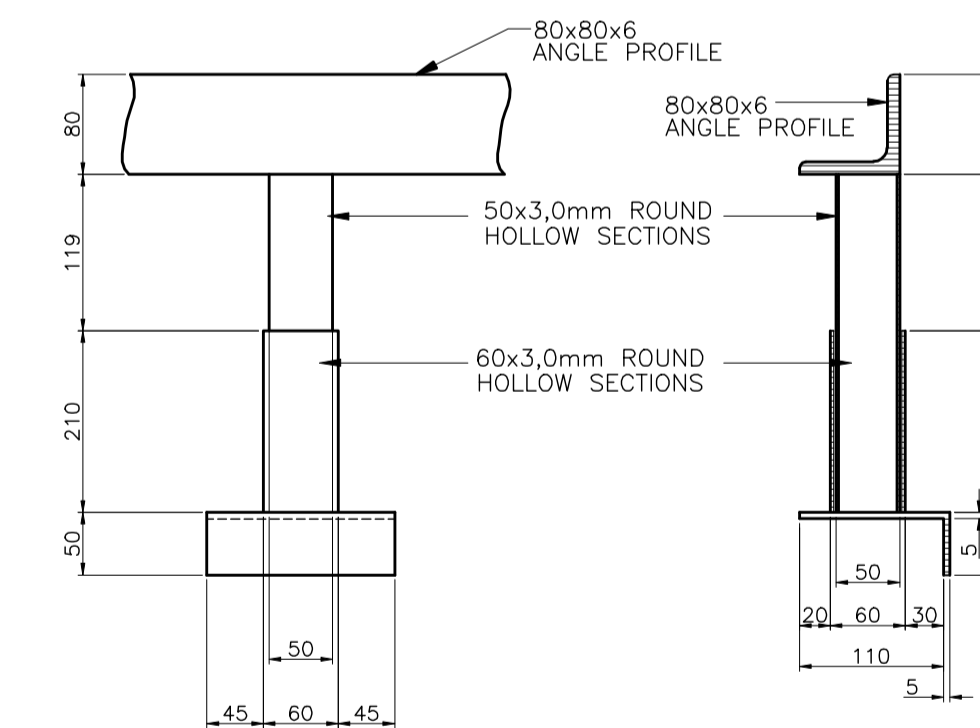

ELEVATION OF STEEL FRAME SECTION A-A

NTS

NTS